

NOTE:

1. ALL WELDING TO COMPLY WITH AS1554.1 CAT SP
2. ALL WELDS 5mm FILLET WELDS
3. ALL HOLLOW SECTION TO COMPLY WITH AS1163 GRD350
4. ALL STEEL PLATE TO COMPLY WITH AS3678
5. TARE WEIGHT 22KG
6. FINISH POWDER COAT GOLDEN YELLOW
7. PROOF LOAD AND MARKINGS TO COMPLY WITH AS4991

ITEM NO.	PART NUMBER	QTY.
1	10401-FRAME SIDE MEMBER	2
2	10401-FRAME TOP MEMBER	2
3	10401-BASE	1
4	10401-BASE ANGLE	2
5	10401-OXY SUPPORT PROFILE	2
6	10401-LIFTING LUG	1
7	10401-8mm CHAIN LINK	2

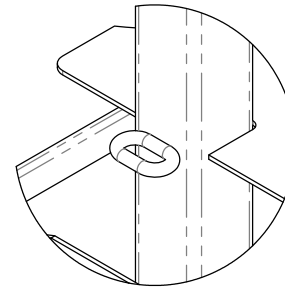
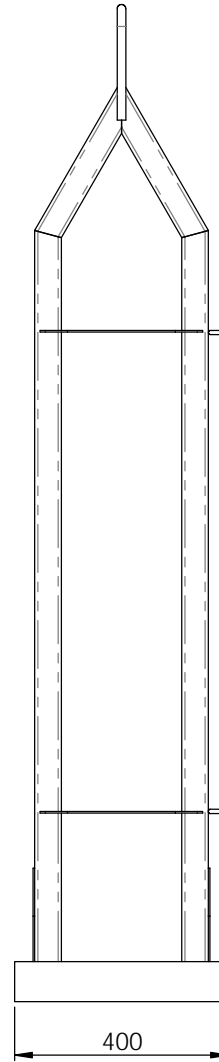
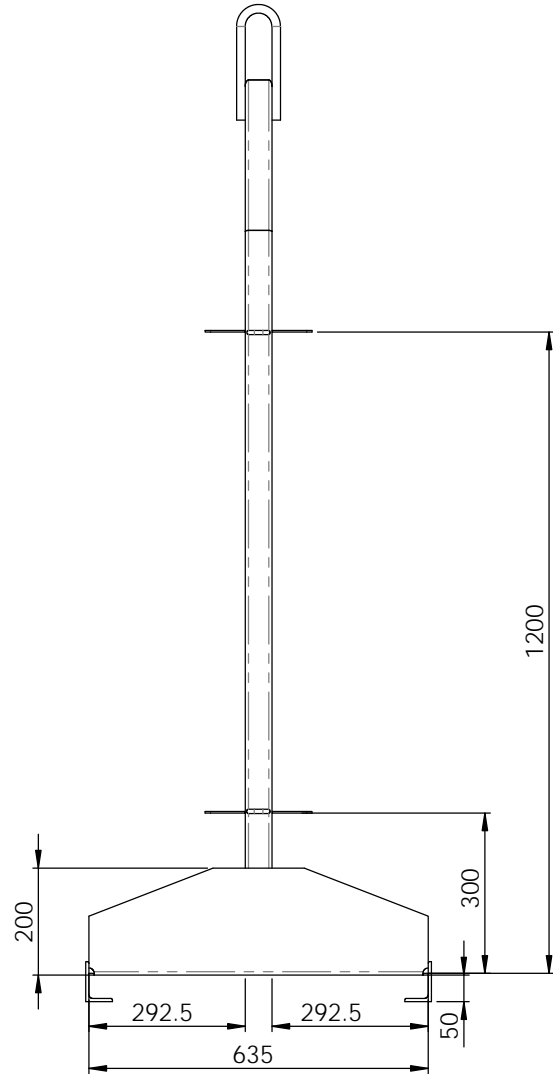

**DETAIL B
SCALE 1 : 3**

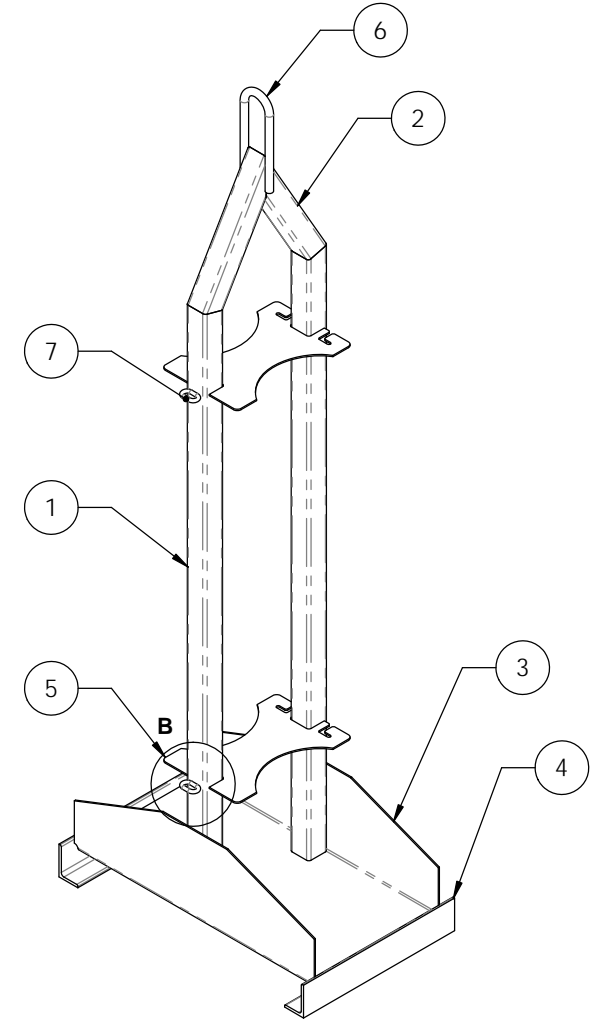

**D.O.T.
ENGINEERING**

1 / 57 PARAMOUNT DRV
WANGARA. 6065
WESTERN AUSTRALIA.

TEL: (08) 9302 4166

FAX: (08) 9302 4099

THIS DRAWING AND THE INFORMATION ON IT
REMAINS THE PROPERTY OF DOT ENGINEERING
WRITTEN PERMISSION MUST BE OBTAINED FROM
DOT ENGINEERING TO COPY OR REPRODUCE
THE WHOLE OR PART OF THIS DRAWING.

DRAWN	RM	TITLE "G" SIZE OXY-OXY GAS BOTTLE LIFTING FRAME		
CHECKED		SIZE 200KG WLL	SCALE 1:10	DATE 22-Apr-11
APPROVED		PROJECT GAS BOTTLES	DWG 10401 - 1	REV 2