

- NOTE:
1. ALL WELDING TO COMPLY WITH AS1554.1 CAT SP
 2. ALL WELDS 5mm FILLET WELDS
 3. ALL HOLLOW SECTION TO COMPLY WITH AS1163 GRD350
 4. ALL STEEL PLATE TO COMPLY WITH AS3678
 5. TARE WEIGHT 57KG
 6. FINISH POWDER COAT GOLDEN YELLOW
 7. PROOF LOAD AND MARKINGS TO COMPLY WITH AS4991

ITEM NO.	PART NUMBER	QTY.
1	10104-BASE	1
2	10104-END FRAME	2
3	10104-OXYGEN RING	2
4	10104-LIFTING BAR	1
5	10104-END CAP	1
6	10104-FRONT GUIDE PLATE	2
7	10104-LIFTING LUG	1
8	10104-BASE SUPPORT	1
9	10104-TINE POCKET	2
10	6mm SPLIT LINK	2
11	10104-ACETYLENE RING	2
12	10104-CENTRE GUIDE PLATE 1	1

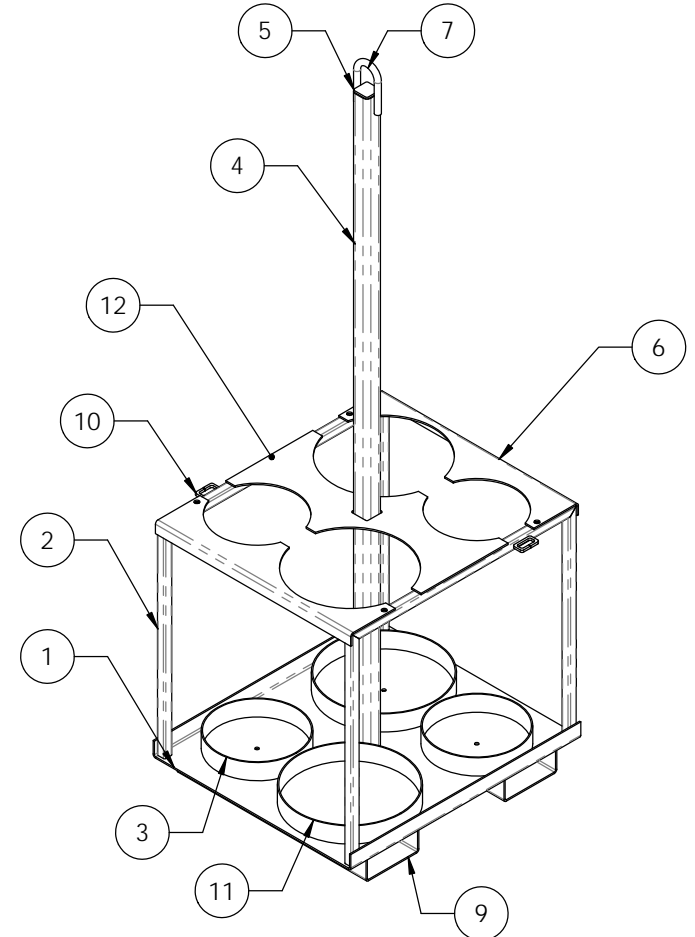
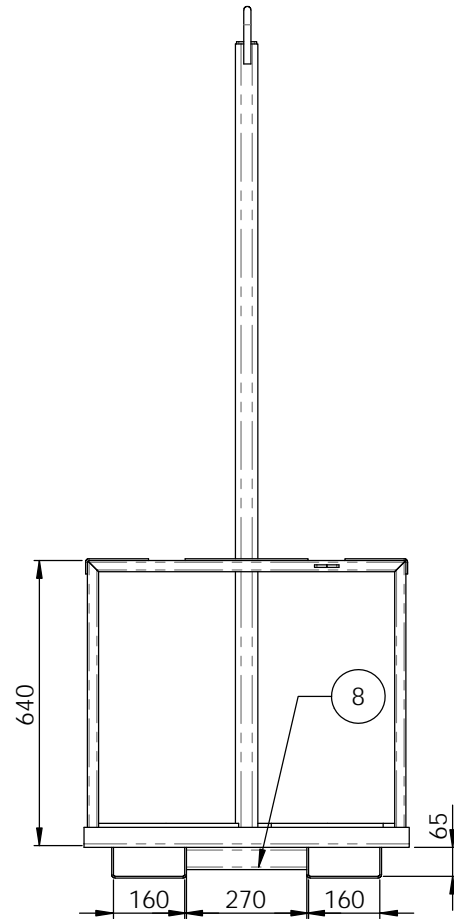
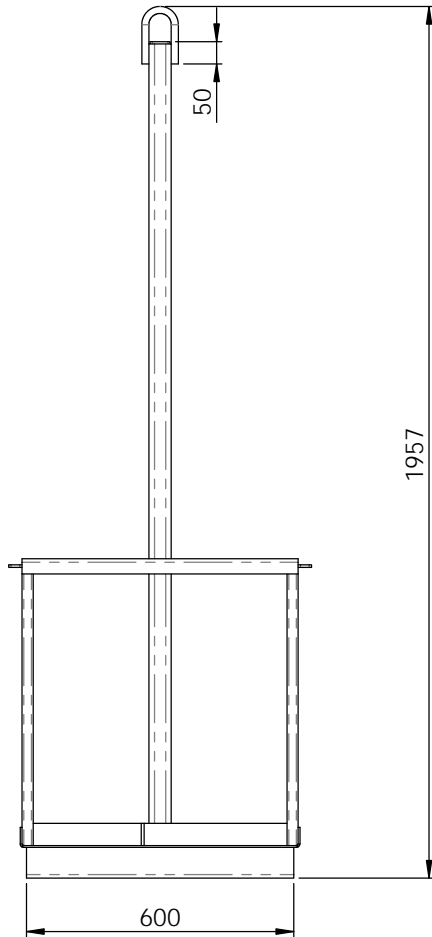

D.O.T.
ENGINEERING

1 / 57 PARAMOUNT DRV
WANGARA. 6065
WESTERN AUSTRALIA.

TEL: (08) 9302 4166

FAX: (08) 9302 4099

THIS DRAWING AND THE INFORMATION ON IT
REMAINS THE PROPERTY OF DOT ENGINEERING
WRITTEN PERMISSION MUST BE OBTAINED FROM
DOT ENGINEERING TO COPY OR REPRODUCE
THE WHOLE OR PART OF THIS DRAWING.

DRAWN

RM

TITLE 2 x 2 "G" SIZE OXY-ACET GAS BOTTLE LIFTING FRAME

CHECKED

SIZE 400KG WLL

SCALE 1:12

DATE 22-Apr-11

APPROVED

PROJECT GAS BOTTLES

DWG 10104 - 1

REV 2