

NOTE:

1. ALL WELDING TO COMPLY WITH AS1554.1 CAT SP
2. ALL WELDS 5mm FILLET WELDS
3. ALL HOLLOW SECTION TO COMPLY WITH AS1163 GRD350
4. ALL STEEL PLATE TO COMPLY WITH AS3678
5. TARE WEIGHT 112KG
6. FINISH POWDER COAT GOLDEN YELLOW
7. PROOF LOAD AND MARKINGS TO COMPLY WITH AS4991

ITEM NO.	PART NUMBER	QTY.
1	10282-ASSEMBLY LIFTING FRAME	1
2	10282-END FRAME	4
3	10282-CENTRE RETAINER PLATE	1
4	10282-RETAINER PLATE	2
5	10282-BASE PLATE	1
6	10282-OXYGEN RING	4
7	10282-ACETYLENE RING	2
8	10282-TINE POCKET	2
9	10282-FLOOR STIFFENER	2
10	6mm SPLIT LINK	2

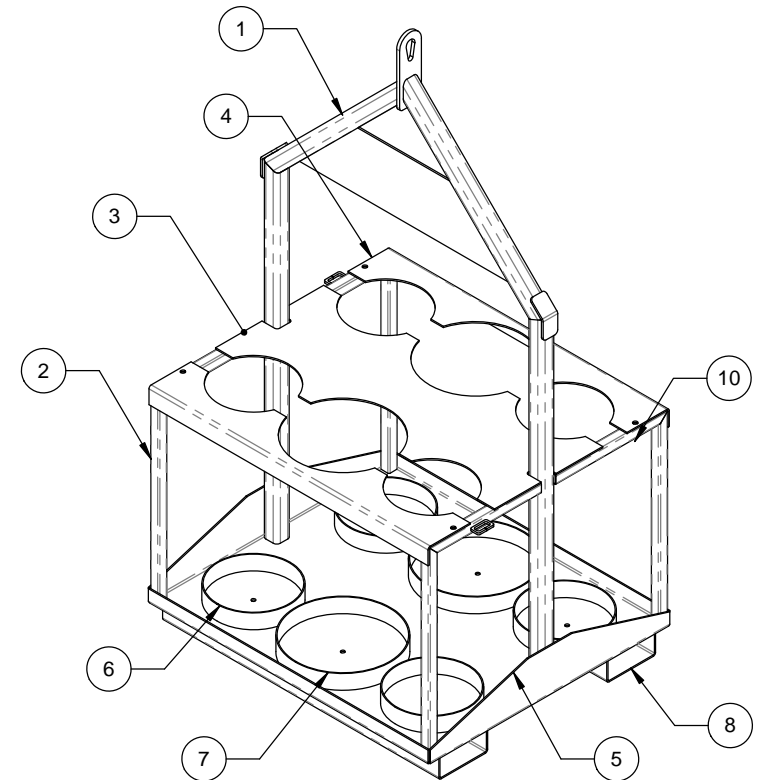
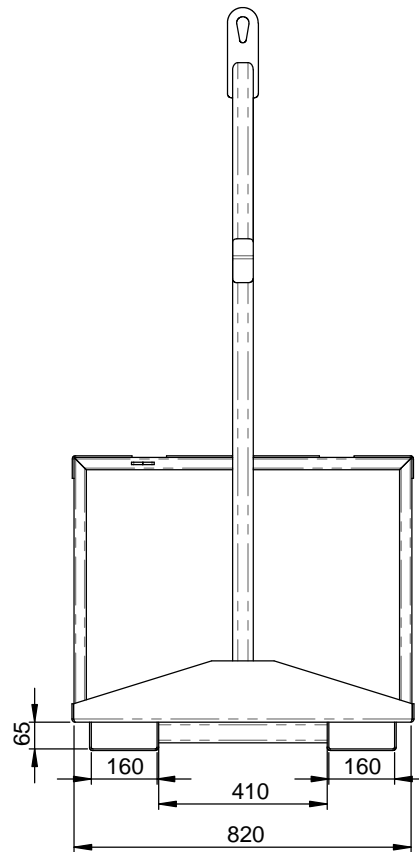
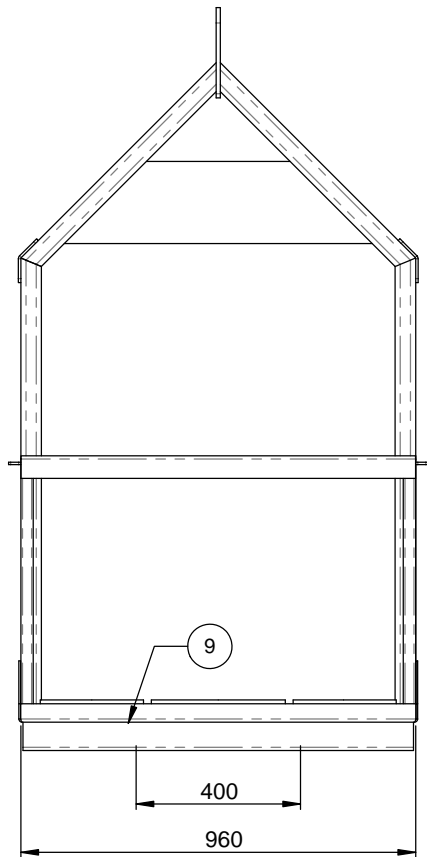

**D.O.T.
ENGINEERING**

1 / 57 PARAMOUNT DRV
WANGARA. 6065
WESTERN AUSTRALIA.

TEL: (08) 9302 4166

FAX: (08) 9302 4099

THIS DRAWING AND THE INFORMATION ON IT
REMAINS THE PROPERTY OF DOT ENGINEERING
WRITTEN PERMISSION MUST BE OBTAINED FROM
DOT ENGINEERING TO COPY OR REPRODUCE
THE WHOLE OR PART OF THIS DRAWING.

DRAWN	RM	TITLE 4 "G" SIZE OXY 2 "G" SIZE ACET GAS BOTTLE FRAME		
CHECKED		SIZE 600KG	SCALE 1:13	DATE 14-Apr-13
APPROVED		PROJECT GAS BOTTLES	DWG 10282 - 1	REV 0